

NX60T871SS

SAMSUNG

Samsung Front Control Slide-in Gas Range with Smart Dial & Air Fry

Upgrade #1 Appliances
Option Code APL0401

6.0 cu. ft. Capacity



Signature Features

Smart Dial

- The new Smart Dial simplifies oven settings in a single dial and intuitively learns based on your cooking preferences.

Air Fry

- Cooking just got healthier* with new Air Fry mode. Using little to no oil, you can quickly prepare your favorite fried foods right in your oven. Air Fry tray included.

*As compared to deep frying.

Convection

- Powerful convection saves you time by cooking food fast and more evenly. Perfect for baking and roasting.

Available Colors



Fingerprint Resistant
Stainless Steel (shown)



Fingerprint Resistant
Black Stainless Steel



Fingerprint Resistant
Tuscan Stainless Steel



Smart Dial



Air Fry

Features

- Smart Dial
- Air Fry, Tray Included
- Convection
- Illuminated Knobs
- Fingerprint Resistant Finish
- Reversible Cast-Iron Griddle
- Large Oven Capacity – 6.0 cu. ft.
- Ready2Fit™ Guarantee
- Temperature Probe
- Wok Ring

- Flexible Cooktop:
Five Burner Cooktop
 - Right Front: 22K BTU Dual Ring
Brass Power Burner
 - Left Front: 16K BTU
 - Right Rear: 5K BTU
 - Left Rear: 9.5K BTU
 - Center (Oval): 10K BTU

Convenience

- Wi-Fi Connectivity
- Voice-Enabled
- Convection Auto Conversion
- Self Clean
- Child Safety Lock
- Delay Start
- Auto Oven Light
- Kitchen Timer
- Sabbath Mode



NX60T8711SS

SAMSUNG

Samsung Front Control Slide-in Gas Range with Smart Dial & Air Fry

Installing Your Range

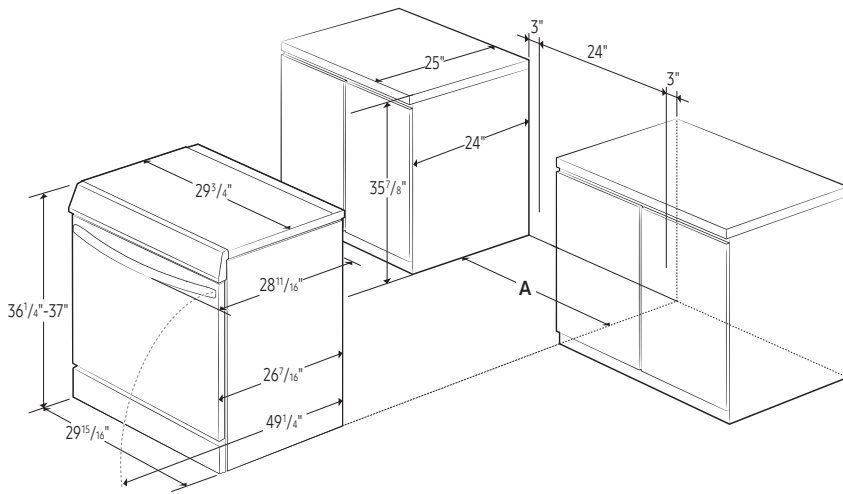

A: Cabinet opening 30"

IMPORTANT: If your cabinets are over 37" high, you must install this range on a hard, heat-resistant support that raises the surface of the range so that it is about even with the countertop.

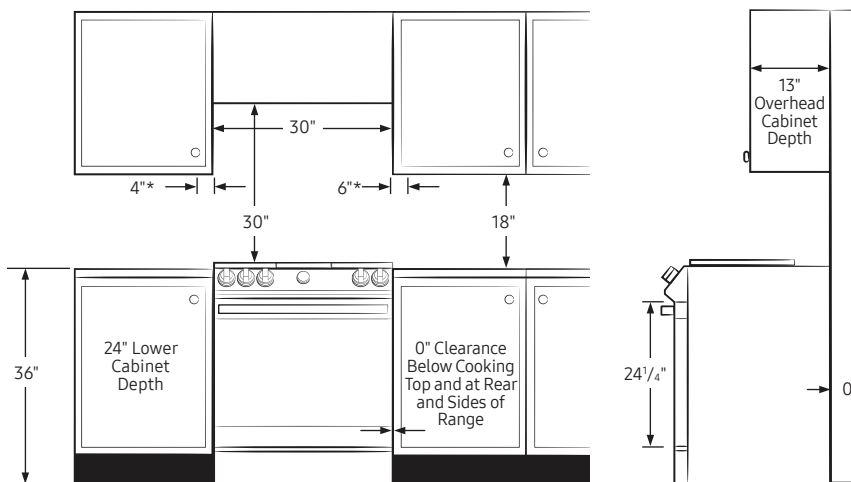

*Side clearance above cooking surface to any objects, i.e., wall.

IMPORTANT: Consult with Installation Manual for detailed instructions before installing. All ranges must be installed with the Anti-Tip device that is included.

Recommended Locations for Gas Piping and Electrical Outlets

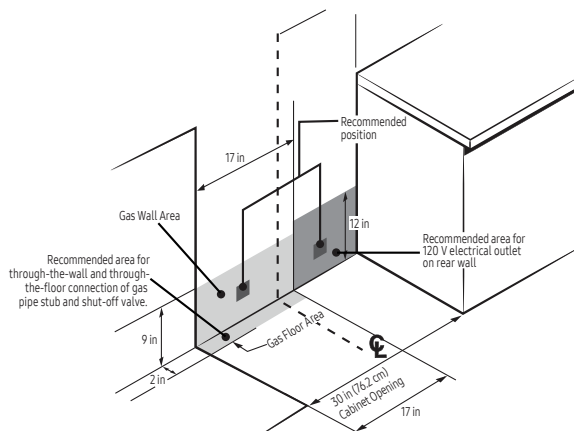

Power Source

120V/60Hz/20A

Total Power (BTU)

62,500 BTU

Black Enamel 5-Burner Cooktop

- Right Front: 22K BTU Dual Ring, Brass
- Left Front: 16K BTU
- Right Rear: 5K BTU
- Left Rear: 9.5K BTU
- Center (Oval): 10K BTU

Oven

- Capacity: 6.0 cu. ft.
- Convection Element/Heater
- Convection Bake
- Convection Roast
- Bake
- Variable Broil: Low/High
- Air Fry
- Bread Proof
- Dehydrate

Warranty

One (1) Year Parts and Labor

Product Dimensions & Weight (WxHxD)

Actual Oven Dimensions:

24¹³/₁₆" x 21⁵/₈" x 19⁵/₈"

Outside Dimensions:

29¹⁵/₁₆" x 36¹/₄-37" (Adjustable) x 28¹¹/₁₆"

Weight: 220 lbs

Shipping Dimensions & Weight (WxHxD)

Dimensions:

33¹/₁₆" x 41³/₄" x 30⁵/₁₆"

Weight: 246 lbs

Color

Model

UPC Code

Fingerprint Resistant

NX60T8711SS

887276409139

Stainless Steel

Fingerprint Resistant

NX60T8711SG

887276409122

Black Stainless Steel

Fingerprint Resistant

NX60T8711ST

887276409269

Tuscan Stainless Steel



Actual color may vary. Design, specifications, and color availability are subject to change without notice. Non-metric weights and measurements are approximate.

©2020 Samsung Electronics America, Inc. 85 Challenger Road, Ridgefield Park, NJ 07660. Tel: 800-SAMSUNG. samsung.com. Samsung is a registered trademark of Samsung Electronics Co. Ltd.

ME19R7041FS

SAMSUNG

1.9 cu. ft. Over-the-Range Microwave with Sensor Cooking



Signature Features

Ceramic Enamel Interior

- Scratch-resistant and easy-to-clean interior.
- Makes removing grease or oil effortless and protects against scratches from daily use.

Sensor Cook

- Automatically adjusts cooking time for optimal results.

LED Display

- Features a digital, blue LED display, complementing any kitchen décor.

Available Colors



Ceramic Enamel Interior



LED Display

Features

- 1.9 cu. ft. Oven Capacity
- 1000 Watts of Cooking Power
- 4-Speed/400 CFM Ventilation System
- Ceramic Enamel Interior
- 10 Power Levels
- Sensor Cook
- Two-Stage Programmable Cooking
- Auto Defrost/Sensor Reheat
- Auto Cook
- LED Display

Convenience

- Clock (12 hr/24 hr) with Daylight Saving Time Adjustment
- Kitchen Timer
- End Signal
- Interior Light: Incandescent (1)
- Cooktop Lighting (Halogen): High/Low/Off
- Vent Fan Control: Boost/Hi/Mid/Lo/Off
- Child Safety Lock
- Sound On/Off
- Eco Mode (Reduces Standby Power)

ME19R7041FS

SAMSUNG

1.9 cu. ft. Over-the-Range Microwave with Sensor Cooking

Dimensions

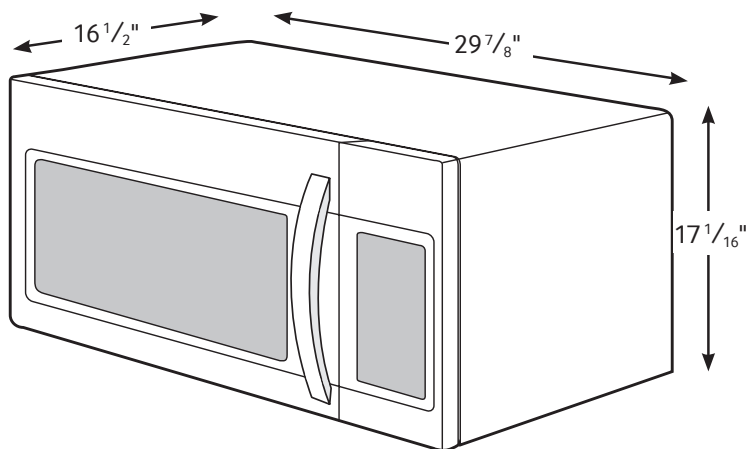

Specifications

- Oven Cavity: 1.9 cu. ft.
- Power Output: 1000W
- Power Consumption: 1700W/14.5 A
- Power Source: 120V/60 Hz
- Control Method: Digital (Membrane Touch)
- Display: LED
- Cooking Control: 10 Power Levels Including Defrost and Sensor Cook
- Cooking Timer: Digital, up to 99 Minutes, 99 Seconds
- Microwave Distribution System: Turntable
- Glass Turntable Diameter: 14 3/16"
- Vent Fan: 4-Speed/400 CFM
- Vent Fan Control: Boost/Hi/Mid/Lo/Off
- Cooktop Lighting: High/Low/Off
- Incandescent Interior Light

Warranty

One (1) Year Parts and Labor
Ten (10) Years Parts on Magnetron

Installing Your Microwave

- This microwave oven is designed for adaptation to the following three types of ventilation:
 - A. Outside Top Exhaust (Vertical Duct)
 - B. Recirculating (Non-Vented Ductless)
 - C. Outside Back Exhaust (Horizontal Duct)
- The space between the cabinets must be 30" wide and free of obstructions.
- This microwave oven is for installation over ranges up to 36" wide.
- The microwave must be level. Use a level to make sure the cabinet bottom is level. If the cabinets have a front overhang only, with no back or side frame, install the mounting plate down the same distance as the front overhang depth. This will keep the microwave level.

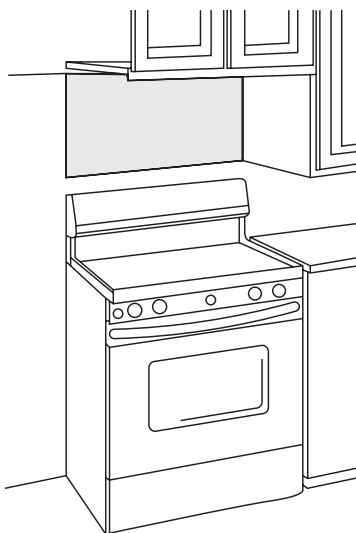

Product Dimensions & Weight (WxHxD)

Cavity Dimensions: 20 13/16" x 10 13/16" x 14 9/16"

Outside Net Dimensions: 29 7/8" x 17 1/16" x 16 1/2"

Weight: 55.4 lbs (Fingerprint Resistant Stainless Steel Models)
53.8 lbs (White and Black)

Shipping Dimensions & Weight (WxHxD)

Dimensions: 33 3/8" x 20 13/16" x 19 3/8"

Weight: 62.4 lbs (Fingerprint Resistant Stainless Steel Models)
60.9 lbs (White and Black)

Color	Model #	UPC Code
Fingerprint Resistant Stainless Steel	ME19R7041FS	887276348056
Fingerprint Resistant Black Stainless Steel	ME19R7041FG	887276348667
Fingerprint Resistant Tuscan Stainless Steel	ME19R7041FT	887276348698
White	ME19R7041FW	887276348704
Black	ME19R7041FB	887276348643

FOR EASIER INSTALLATION AND PERSONAL SAFETY, WE RECOMMEND THAT TWO PEOPLE INSTALL THIS MICROWAVE OVEN. IMPORTANT: Do not grip or use handle during installation.

NOTE: If your cabinet is metal, use the nylon grommet around the power cord hole to prevent cutting of the cord.

NOTE: We recommend using filler blocks if the cabinet front hangs below the cabinet bottom shelf.

IMPORTANT: If filler blocks are not used, case damage may occur from overtightening screws.

NOTE: When mounting the microwave oven, thread power cord through hole in bottom of top cabinet. Do not pinch cord or lift oven by pulling cord.

DW80R7061

SAMSUNG

Samsung StormWash™ 42 dBA Dishwasher



Signature Features

StormWash™

- Powerful rotating spray jets clean at every angle for tough to reach spots.

Whisper Quiet Cleaning

- Virtually silent washes for a quieter kitchen at 42 dBA sound level.

AutoRelease™ Door

- At the end of the cycle, the door automatically opens to circulate air and improve drying performance.

Available Colors



Fingerprint Resistant
Stainless Steel



Fingerprint Resistant
Black Stainless Steel (shown)



StormWash™



AutoRelease™ Door

Features

- 3rd Rack
- Fingerprint Resistant Stainless Finish
- One-Touch Adjustable Racking System
- Premium Ball Bearing Rack
- Digital Touch Control
- Sanitize Cycle
- 6 Wash Cycles
- 6 Options
- Half-Load Cycle
- Express Cycle: 60 Minutes
- Full Stainless Steel Interior
- 15 Place Settings
- 3 Spray Wash Arms (Upper, Middle, Lower)
- ENERGY STAR® rated

Convenience

- Control Lock
- Cycle Progress Indicator
- Delay Start
- Digital Leak Sensor

Rating

ENERGY STAR®-rated:
239 kWh/yr

DW80R7061

SAMSUNG

Samsung StormWash™ 42 dBA Dishwasher

Installation Specifications

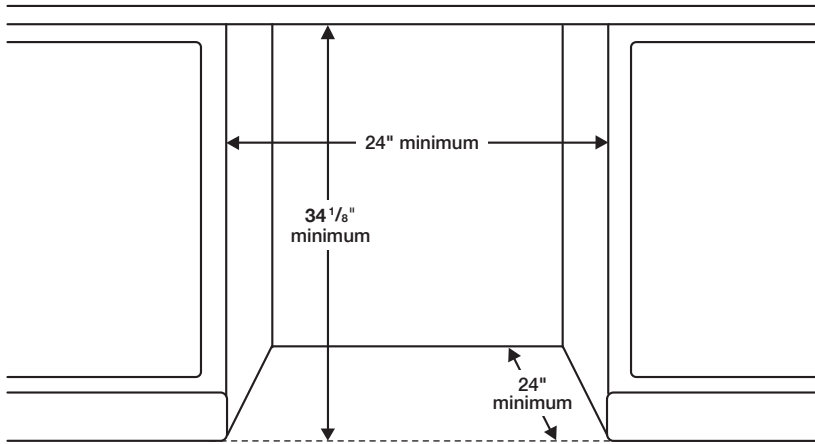

Dimensions

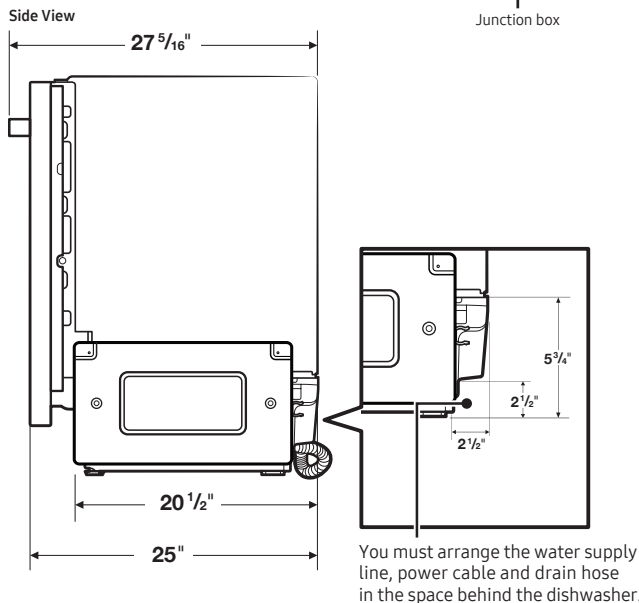
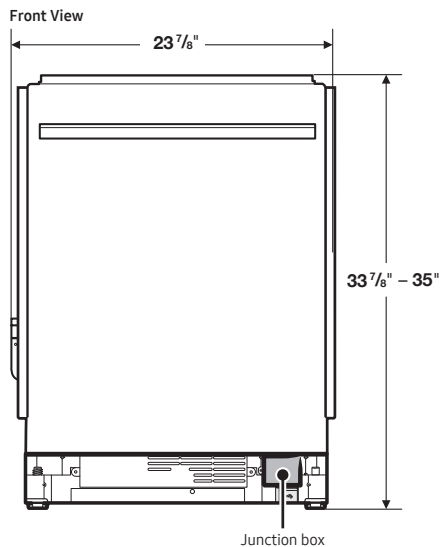

Features

- 6 Wash Cycles: Auto, Normal, Heavy, Delicate, Express 60, Rinse Only
- 6 Options: Half-Load Wash (Lower Rack), StormWash™, Hi-Temp Wash, Sanitize (Anti-bacterial – NSF), Delay Start, Control Lock
- AutoRelease™ Door
- Hidden Heat Element
- Stainless Steel Interior Tub

Convenience

- Control Lock
- Digital Water Leakage Sensor
- 3rd Rack
- One-Touch Adjustable Racking System
- Silverware Basket
- Upper Rack: Foldable Cup Shelves, 2 Adjustable Tines
- Lower Rack: Fold-Down Tines

Warranty

One (1) Year All Parts and Labor

Five (5) Year Limited on Printed Circuit Board and Interior Nylon Racks

Product Dimensions & Weight (WxHxD)

Dimensions (height is adjustable):

23⁷/₈" x 33⁷/₈" – 35" x 24³/₄"

Weight: 95 lbs

Shipping Dimensions & Weight (WxHxD)

Dimensions:

26" x 35" x 29¹/₂"

Weight: 106 lbs

Color

Fingerprint Resistant
Stainless Steel

Model

DW80R7061US

UPC Code

887276337777

Fingerprint Resistant
Black Stainless Steel

Model

DW80R7061UG

887276335087