

NX60T831SS

SAMSUNG

Samsung Front Control Slide-in Gas Range with Convection

6.0 cu. ft. Capacity

Std. Appliance Pkg.
Option Code APL0005



Signature Features

Convection

- Powerful convection saves you time by cooking food fast and more evenly. Perfect for baking and roasting.

Ready2Fit™ Guarantee

- If your Samsung Front Control Slide-In Range doesn't fit your 30" Freestanding Range cutout, enjoy \$100* on us to cover any countertop modification costs.

*Visit samsungpromotions.com/SlideInReady2Fit for details.

Fingerprint Resistant Finish

- Fingerprint resistant, for an everyday beautiful finish.

Available Colors



Fingerprint Resistant
Stainless Steel (shown)



Fingerprint Resistant
Black Stainless Steel

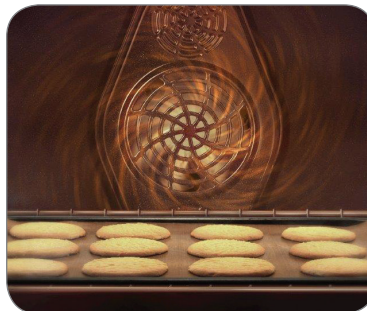

Convection



Ready2Fit™ Guarantee

Features

- Convection
- Ready2Fit™ Guarantee
- Fingerprint Resistant Finish
- 2 Power Burners
- Integrated Cast-Iron Griddle
- Large Oven Capacity – 6.0 cu. ft.
- Glass Touch Controls
- Edge-to-Edge Grates
- Storage Drawer

- Flexible Cooktop:
 - Five Burner Cooktop
 - Right Front: 17K BTU
 - Left Front: 16K BTU
 - Right Rear: 5K BTU
 - Left Rear: 9.5K BTU
 - Center (Oval): 10K BTU

Convenience

- Wi-Fi Connectivity
- Voice-Enabled
- Self Clean
- Child Safety Lock
- Delay Start
- Auto Oven Light
- Kitchen Timer
- Sabbath Mode



NX60T8311SS

SAMSUNG

Samsung Front Control Slide-in Gas Range with Convection

6.0 cu. ft. Capacity

Installing Your Range

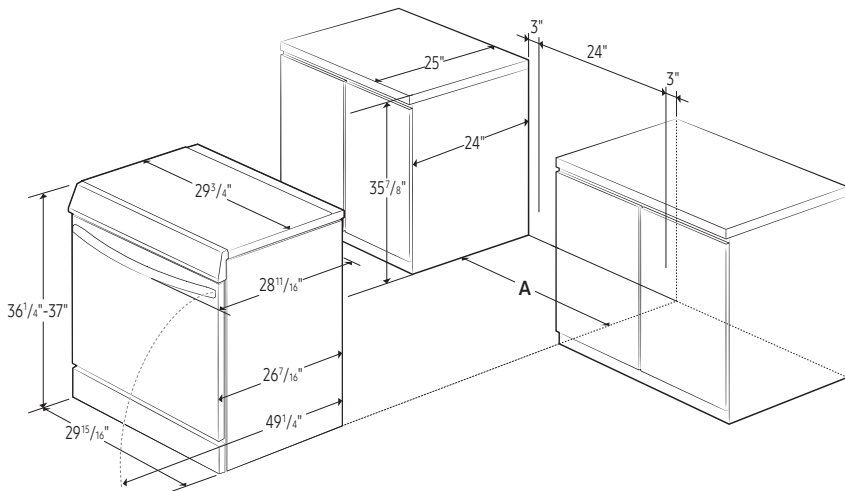

A: Cabinet opening 30"

IMPORTANT: If your cabinets are over 37" high, you must install this range on a hard, heat-resistant support that raises the surface of the range so that it is about even with the countertop.

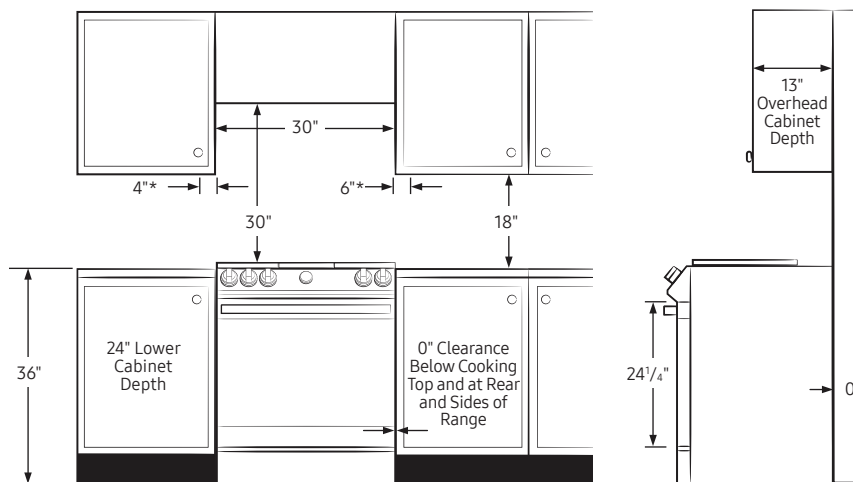

*Side clearance above cooking surface to any objects, i.e., wall.

IMPORTANT: Consult with Installation Manual for detailed instructions before installing. All ranges must be installed with the Anti-Tip device that is included.

Recommended Locations for Gas Piping and Electrical Outlets

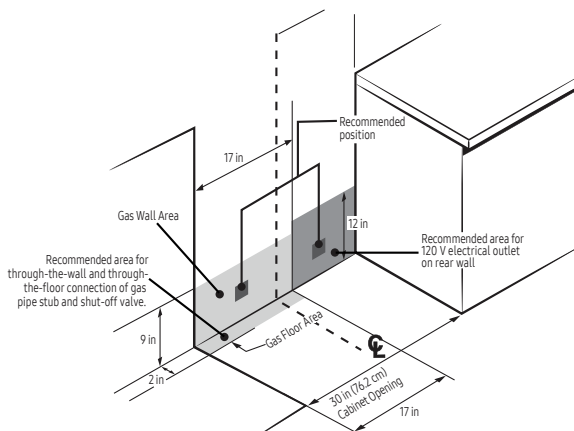

Power Source

120V/60Hz/20A

Total Power (BTU)

57,500 BTU

Black Enamel 5-Burner Cooktop

- Right Front: 17K BTU
- Left Front: 16K BTU
- Right Rear: 5K BTU
- Left Rear: 9.5K BTU
- Center (Oval): 10K BTU

Oven

- Capacity: 6.0 cu. ft.
- Convection Bake
- Convection Roast
- Bake
- Variable Broil: Low/High
- Bread Proof
- Dehydrate

Warranty

One (1) Year Parts and Labor

Product Dimensions & Weight (WxHxD)

Oven Interior Dimensions:

24¹³/₁₆" x 21⁵/₈" x 19⁵/₈"

Outside Dimensions:

29¹⁵/₁₆" x 36¹/₄-37" (Adjustable) x 28¹¹/₁₆"

Weight: 205 lbs

Shipping Dimensions & Weight (WxHxD)

Dimensions:

33¹/₁₆" x 41³/₄" x 30⁵/₁₆"

Weight: 230 lbs

Color

Fingerprint Resistant

Stainless Steel

Model

NX60T8311SS

UPC Code

887276409214

Fingerprint Resistant

Black Stainless Steel

NX60T8311SG

887276409207



Actual color may vary. Design, specifications, and color availability are subject to change without notice. Non-metric weights and measurements are approximate.

©2020 Samsung Electronics America, Inc. 85 Challenger Road, Ridgefield Park, NJ 07660. Tel: 800-SAMSUNG. samsung.com. Samsung is a registered trademark of Samsung Electronics Co. Ltd.

ME17R7021ES

1.7 cu. ft. Over-the-Range Microwave

SAMSUNG



Signature Features

1.7 cu. ft. Capacity

- The 1.7 cu. ft. capacity of this microwave accommodates a variety of snacks and meal items and lets you prepare foods quickly and easily.

Fingerprint Resistant

- Special coated exterior ensures your microwave remains spotless even with daily use.

300 CFM Ventilation System

- Powerful 300 CFM ventilation fan quickly and quietly eliminates food odors.

Available Colors

 Fingerprint Resistant
Stainless Steel (shown)

 Fingerprint Resistant
Black Stainless Steel

 White

 Black



LED Display



300 CFM Ventilation System

Features

- 1000 Watts of Cooking Power
- LED Display
- Charcoal/Grease Vent Filter
- 10 Power Levels
- Two-Stage Programmable Cooking
- Auto Defrost/Auto Reheat
- Auto Cook
- Microwave Distribution System: Turntable

Convenience

- Kitchen Timer
- Clock (12 hr/24 hr) with Daylight Saving Time Adjustment
- Child Safety Lock
- Reminder End Signal
- Interior Light: Incandescent (1)
- Cooktop Lighting: High/Low/Off
- Vent Fan Control: High/Low/Off
- Sound On/Off
- Eco Mode (Reduces Standby Power)

ME17R7021ES

SAMSUNG

1.7 cu. ft. Over-the-Range Microwave

Dimensions

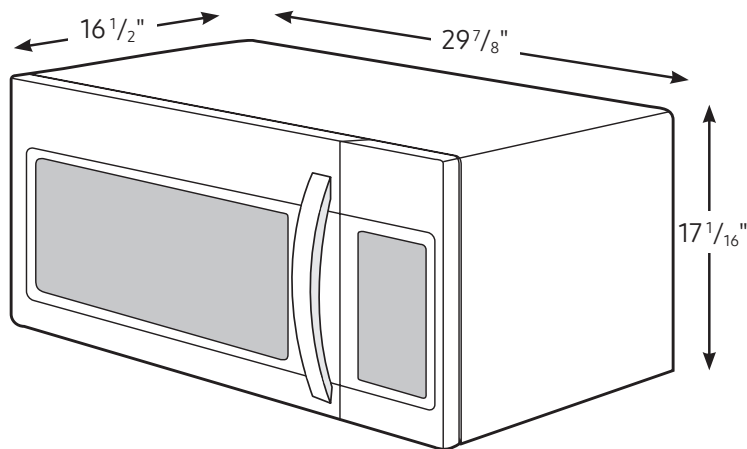

Installing Your Microwave

- This microwave oven is designed for adaptation to the following three types of ventilation:
 - A. Outside Top Exhaust (Vertical Duct)
 - B. Recirculating (Non-Vented Ductless)
 - C. Outside Back Exhaust (Horizontal Duct)
- The space between the cabinets must be 30" wide and free of obstructions.
- This microwave oven is for installation over ranges up to 36" wide.
- The microwave must be level. Use a level to make sure the cabinet bottom is level. If the cabinets have a front overhang only, with no back or side frame, install the mounting plate down the same distance as the front overhang depth. This will keep the microwave level.

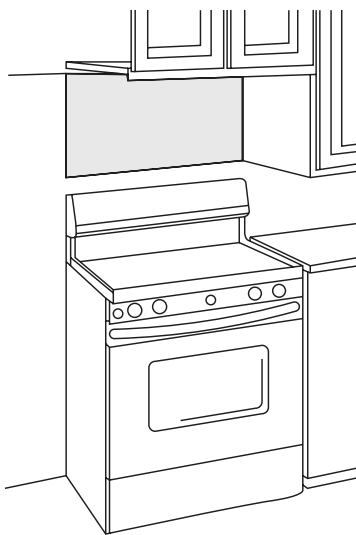

Specifications

- Oven Cavity: 1.7 cu. ft.
- Power Output: 1000W
- Power Consumption: 1580W/13.5 A
- Power Source: 120V/60 Hz
- Control Method: Digital (Membrane Touch)
- Display: LED
- Cooking Control: 10 Power Levels Including Defrost
- Cooking Timer: Digital, up to 99 Minutes, 99 Seconds
- Microwave Distribution System: Turntable
- Glass Turntable Diameter: 11 1/2"
- Vent Fan: 300 CFM
- Vent Fan Control: High/Low/Off
- Cooktop Lighting: High/Low/Off

Warranty

One (1) Year Parts and Labor
Ten (10) Years Parts on Magnetron

Product Dimensions & Weight (WxHxD)

Cavity Dimensions: 19⁵/₁₆" x 9⁵/₈" x 14³/₈"

Outside Net Dimensions: 29⁷/₈" x 17¹/₁₆" x 16¹/₂"

Weight: 48.3 lbs. (Fingerprint Resistant Stainless Steel,
Fingerprint Resistant Black Stainless Steel)
47.0 lbs. (White, Black)

Shipping Dimensions & Weight (WxHxD)

Dimensions: 33³/₈" x 20¹³/₁₆" x 19³/₈"

Weight: 55.1 lbs. (Fingerprint Resistant Stainless Steel,
Fingerprint Resistant Black Stainless Steel)
54.0 lbs. (White, Black)

Color	Model #	UPC Code
Fingerprint Resistant Stainless Steel	ME17R7021ES	887276348049
Fingerprint Resistant Black Stainless Steel	ME17R7021EG	887276390024
White	ME17R7021EW	887276348636
Black	ME17R7021EB	887276348612

FOR EASIER INSTALLATION AND PERSONAL SAFETY, WE RECOMMEND THAT TWO PEOPLE INSTALL THIS MICROWAVE OVEN. IMPORTANT: Do not grip or use handle during installation.

NOTE: If your cabinet is metal, use the nylon grommet around the power cord hole to prevent cutting of the cord.

NOTE: We recommend using filler blocks if the cabinet front hangs below the cabinet bottom shelf.

IMPORTANT: If filler blocks are not used, case damage may occur from overtightening screws.

NOTE: When mounting the microwave oven, thread power cord through hole in bottom of top cabinet. Do not pinch cord or lift oven by pulling cord.

DW80R2031US

SAMSUNG

Samsung Dishwasher with Integrated Digital Touch Controls



Signature Features

Digital Touch Controls

- Digital touch controls make it easy to select functions with a gentle touch

Adjustable Rack

- Height adjustable upper rack makes it easy to accommodate various dishware shapes and sizes

Stainless Steel Door

- The interior door is covered with stainless steel that's more durable

Available Color



Stainless Steel



Digital Touch Controls



Stainless Steel Interior Door

Features

- Fully Integrated Top Control
- Advanced Wash System
- ENERGY STAR® rated: 255 kWh/Year
- Touch Control
- 4 Wash Cycles
- 5 Options
- 14 Place Settings
- 55 dBA Noise Level

Convenience

- Control Lock
- Delay Start
- Height-Adjustable Upper Rack
- Digital Water Leakage Sensor

DW80R2031US

SAMSUNG

Samsung Dishwasher with Integrated Digital Touch Controls

Installation Specifications

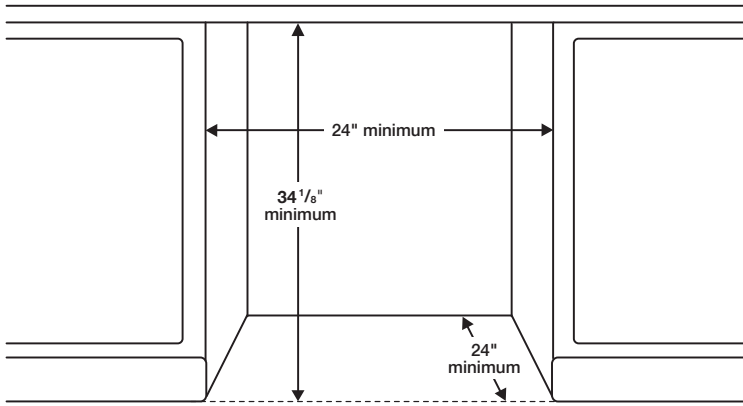

Features

- 4 Wash Cycles: Auto, Normal, Heavy, Express 60
- 5 Options: Hi-Temp Wash, Sanitize (Anti-Bacterial-NSF), Delay Start, Control Lock, Heated Dry

Convenience

- Control Lock
- Digital Water Leakage Sensor
- Height-Adjustable Upper Rack
- Polypropylene Racking
- Silverware Basket

Warranty

One (1) Year All Parts and Labor
Five (5) Year Limited on Printed Circuit Board

Product Dimensions & Weight (WxHxD)

Dimensions: 23³/₄" x 33³/₄" x 24⁵/₈"
Weight: 64 lbs

Shipping Dimensions & Weight (WxHxD)

Dimensions: 26" x 35" x 29¹/₇"
Weight: 73.9 lbs

Dimensions

Side View

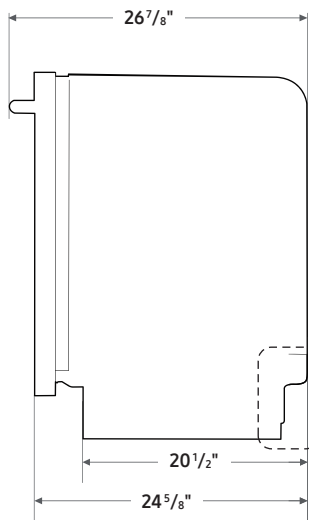

Rear View

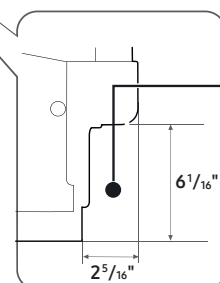
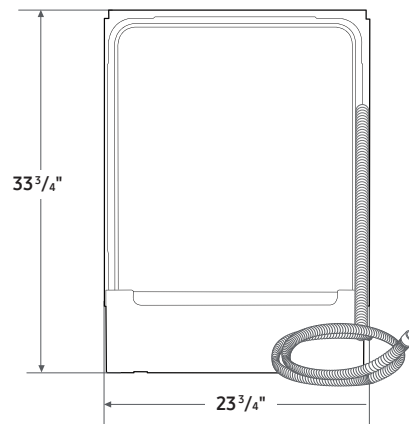

The water supply line, power cable and drain hose should go through this space behind the dishwasher. Then, the power cable runs in channels under the dishwasher to connections in the front.

Color

Stainless Steel

Model

DW80R2031US

UPC Code

887276305004